

GRAVIX

INSTALLATION & QC MANUAL

February 27, 2019



PATENTED PRODUCT BY

**EARTH WALL
PRODUCTS**

LICENSED BY

DECAST

II. TABLE OF CONTENTS

I. INTRODUCTION -----	3
II. DISCLAIMER -----	3
III. HOW THE SYSTEM WORKS -----	4
IV. DEFINITIONS -----	5
V. RESPONSIBILITES -----	7
VI. SAFETY -----	8
VII. COMPONENTS OF THE SYSTEM -----	9
VIII. EQUIPMENT AND MATERIALS -----	10
IX. CONSTRUCTION PROCEDURES -----	11
i. STEP I -----	14
ii. STEP II -----	14
iii. STEP III -----	16
iv. STEP IV -----	17
v. STEP V -----	21
X. TOP UNIT PLACEMENT -----	27
XI. STONE BACKFILL OPTION -----	27
XII. REPAIR DETAIL -----	29
XIII. BATTERED STRUCTURES -----	30
XIV. CONSTRUCTION TOLERANCE -----	31
XV. TROUBLESHOOTING -----	32
XVI. INSTALLATION CHECKLIST -----	33

I. INTRODUCTION

Gravix is a precast concrete prefabricated modular retaining wall system by Earth Wall Products, LLC (EWP) developed for the Highway/Transportation market. The following Installation manual has been prepared to provide guidance and assistance in the construction using the Gravix wall system.

Earth Wall Products, LLC
Marietta, Georgia USA
Tel: 678 594 3451
Website: www.earthwallproducts.com

Licensee
DECAST Ltd.
Utopia, ON
Tel: 705 734 2892
Website: www.decastltd.com

The contents of the installation manual should be thoroughly reviewed by the installation contractor, superintendent, foreman, quality control field personnel and anyone else who is involved with the construction of the Gravix retaining wall.

The Gravix retaining wall system is protected under Domestic and International Patents and Trademarks. Gravix is the intellectual property of Earth Wall Products, LLC. Reproduction of the contents of this document in whole or in part without the written consent of Earth Wall Products, LLC is strictly prohibited. All rights reserved. Gravix and the "I" shape are registered trademarks of Earth Wall Products, LLC. Copyright 2012 by Earth Wall Products, LLC.

II. DISCLAIMER

The following manual does not relieve the contractor or any construction personnel of the responsibility to adhere to construction plans, specifications and contract documents. The engineer of record must be consulted with any questions or conflicts in understanding the proper installation and construction procedures. When conflicts arise between the information contained herein and the project specific engineered construction drawings and specifications, the project specific construction plans and specifications shall govern.

It is the contractor's responsibility to devise and execute a project specific erection sequence, unit unloading, handling and placement procedure. The contractor is responsible for fall protection and the means and methods to protect the safety of the construction personnel on site. Compliance with the following guidelines and recommended procedures does not relieve the contractor of his/her responsibility to adhere to the project plans, specifications and contract documents.

III. HOW THE SYSTEM WORKS

The large precast Gravix unit acts as a “bin wall” system and possesses unprecedented engineering efficiency by the patented shape to use the soil backfill weight for stability and to resist earth pressure. Hence the Gravix retaining wall is a true gravity system with the weight of the concrete units along with the soil backfill being used to resist overturning and sliding forces. The size of the Gravix system has a face area of 1.22m (4') high and 2.44m (8') wide with the depth of the stems varying between 1.22m and 6.10m. The stem depth is based upon the wall height and loading conditions. The Gravix retaining wall system follows established Industry guidelines to provide a quality and true sustainable earth retaining structure. The unique features of the Gravix retaining wall system includes:

- Large 2.97m² (32ft²) face area coverage per unit installed
- Vertical face alignment as well as battered
- No separate coping required
- Continuous vertical joints so foundation differential settlement will not adversely impact wall performance
- True gravity system, unlike MSE relying on friction of select backfill
- Various face impressions possible with interchangeable mold face liners
- Capable of inside and outside radii including turns and 90 degree corners
- Constructible with an integrated traffic barrier with the top most Gravix unit
- Automatic vertical alignment control by means of interlocking shear nodes on the bottom of all units

IV. DEFINITIONS

AASHTO - American Association of State Highway Transportation Officials who is the author of the recognized national standard for the design and construction of bridges and related structures including retaining walls.

Blanket Drain - An area drain constructed with free draining stone used to collect subsurface water from the surrounding soil and carry to outlet pipes for safe exit outside of the wall zone. Acceptable free draining stone gradation is specified by the engineer of record along with encasing filter fabric.

Canadian Highway Bridge Design Code (CHBDC) - Canadian Highway Bridge Design Code applies to the design, evaluation and structural rehabilitation design of fixed & movable highway bridges and establishes safety & reliability levels that are consistent across all jurisdictions in Canada.

Concrete Swale - A cast-in-place concrete lined ditch located above and directly behind the top of a retaining wall to carry surface runoff around the retaining wall face to prevent overtopping of runoff from coming over the front face of a retaining wall.

Contract Documents - The Contract agreement including the design drawings, construction specifications, quantity takeoff and submittals. This would also include all addendums, letters, emails and communication between parties.

Contractor - The individual, corporation or joint venture undertaking the execution of the work under the terms of the contract and acting directly through its agency or employees.

Drawings - The signed and sealed plans prepared by the engineer of record. The plans typically include profiles, elevation views, typical cross sections and details for the final proposed retaining wall.

Engineer of record - The Professional Engineer who has prepared under his/her direct supervision and attested to its completeness with their signature and seal, the retaining wall design construction drawings and specifications.

Filter Fabric - Needle punched nonwoven polypropylene geosynthetic geotextile material used to provide a separator between the backfill soils and drainage stone. Also used at the joints between concrete units to allow the transmission of water but retain the backfill soil particles.

Foundation Soil - The soil mass supporting the wall base which is typically undisturbed in-situ soils. The foundation soils must be approved by the inspecting geotechnical engineer to meet the engineer of records bearing capacity requirements prior to wall construction.

Gravix Unit - The precast concrete prefabricated modular unit used to construct the gravity mass of the proposed retaining wall.

Inspector - The authorized representative assigned to make a detailed inspection of any and all portions of the retaining wall construction.

Leveling Pad - A cast-in-place unreinforced concrete pad to assist in the leveling of the front face of the first course of Gravix units. The leveling pad alignment must follow the prescribed survey layout and as depicted on the project specific design construction drawings.

Lifting Device - A steel lifting bracket available for use in unloading and placing the Gravix unit into the retaining wall.

Ministry of Labour (MOL) - The Ministry of Labour works to prevent workplace injuries and illnesses, promotes and enforces employment standards, and helps settle workplace disputes and collective agreements in Ontario.

Nodes - The two protruding feet beneath the front portion of the stem resting directly behind the front face at the bottom of the Gravix unit.

Owner - The agency, department, corporation or person which has executed the contract documents and will make payment of the work performed.

Shim - A 100mm by 100mm by 3mm thick plastic insert used to level and maintain alignment of the Gravix units.

Soil Compaction - Densification and consolidation of the soil being used in the construction of the retaining wall. Proper soil compaction is essential to the successful performance of retaining wall structures. Soils must be compacted in specified lifts to achieve maximum soil density and to validate the design. Specifications with respect to the degree of minimum soil compaction required is as outlined by the engineer of record.

Specifications - An explanation of the materials and installation requirements for the retaining wall construction as prepared by the engineer of record. The written material containing the standard and special provisions pertaining to the quantities and qualities of materials for the completed retaining wall structure.

Stem - The portion of the Gravix precast unit that protrudes into the backfill soil of the gravity mass. The stem has the triangular protrusions which extend laterally to develop arching within the soil backfill placed between adjacent Gravix units.

Structural Backfill - In situ or borrow soils used to fill around the Gravix units that meet the design specifications of the project as prescribed by the engineer of record.

V. RESPONSIBILITIES

The responsibilities outlined below are typical and are not to replace the detailed responsibilities as outlined in the project specific contract documents. The responsibilities outlined below are provided as a guide.

ENGINEER - The engineer of record is responsible for the development of the Gravix retaining wall design, construction drawings and specifications. Only the engineer can enforce the requirements of the drawings and specifications. The engineer of record will make all decisions with regards to discrepancies between drawings, specifications, contract documents and this installation and quality control procedures manual. The contractor and/or owner may require technical assistance on site. The engineer of record must have experienced personnel available to provide onsite assistance.

MANUFACTURER - The manufacturer is responsible for the proper casting of the Gravix units to meet the design requirements and to be within acceptable tolerances as outlined in the design and manufacturing specifications. The manufacturer may also be responsible for the transportation of the units to the jobsite. Typically, unloading will be by the contractor at the jobsite. The manufacturer must assist the contractor with scheduling of materials delivery to the jobsite.

CONTRACTOR - It is the contractor's responsibility to complete the retaining wall construction in strict conformance to the specifications, drawings and contract documents. The contractor is responsible for jobsite safety, fall protection, procedures, hoisting, unloading and installation of the Gravix units. The contractor must check materials upon delivery to assure that proper materials have been received. Any questions or conflicts the contractor may have concerning the retaining wall construction must be brought to the attention of the engineer of record for clarification and direction. Material scheduling and coordination is to be handled by the contractor. Technical advisors may be requested and provided by the Engineer of Record for assistance on site as requested by the contractor.

INSPECTOR - The owner supplied geotechnical testing firm is hired to provide construction testing services and must follow the specification requirements and alert the owner, engineer and contractor in writing of all findings, testing results and any observed nonconformance issues arising during construction.

VI. SAFETY

The contractor is solely responsible for construction jobsite safety. Below is an outline of recommended safety concerns for the use of the contractor in making final safety decisions and procedures.

JOBSITE HOISTING AND UNLOADING

1. Upon arrival of the truck carrying the Gravix units, examine the load for any shifting, sliding or unstable units prior to removal of tie straps.
2. All personnel including delivery personnel should be equipped with proper personal safety equipment.
3. Flagman and adequate room from active traffic must be in place prior to arrival of the truck carrying materials to be unloaded.
4. Unloading should always occur on level ground which may not be in close proximity to the wall location. While unloading near the wall may allow quicker unload time, safety must be considered first.
5. The truck being used to carry the Gravix units to the jobsite must remain stationary during unloading.
6. Hoisting and lifting equipment must be of the size and strength to adequately remove the Gravix units from the truck. Refer to Unit Size Chart in this procedures manual to find the units weights and dimensions.
7. Equipment being used to unload the Gravix units must be checked for excessive wear and signs of damage.
8. At no time should personnel be allowed to be under a suspended unit being unloaded or placed on the retaining wall.

VII. COMPONENTS OF THE SYSTEM

Gravix retaining wall earth structures consist of the following components:

Concrete leveling Pad - A cast in place concrete unreinforced leveling pad 200mm thick and 300mm wide. The leveling pad serves as a smooth level surface for placing the front face portion of the Gravix unit. The leveling pad is typically installed along the wall length at a horizontal alignment parallel with the roadway grade when using a traffic barrier unit at the top of the wall. When not using a traffic barrier above the wall, the leveling pad is typically installed horizontal or level.

Blanket Drain - Free draining stone placed approximately 200mm thick behind the leveling pad extending to the back of the lowest course of Gravix units. The blanket drain acts as a subsurface drain to prevent the buildup of hydrostatic pressure behind the wall as well as to provide a level surface for the stem portion of the Gravix unit to rest.

Precast Concrete Gravix Units - Precast Concrete retaining wall units formed for the specific use of constructing a gravity retaining wall. The units are manufactured with a minimum 28 day compressive strength of 45MPa concrete. Entrained air content shall be between 5 and 8%. Reinforcing steel shall be grade 400W.

Traffic Barrier Unit - Gravix has a top unit which consist of a traditional reinforced concrete traffic barrier to provide vehicle impact resistance. When using a traffic barrier top unit, the leveling pad is typically installed parallel to the roadway grade.

Drainage Swale - Proper drainage on top of the retaining wall is important to protect the wall mass from ponding and potential backfill saturation as well as to prevent over-topping of the wall face. A concrete lined swale is recommended behind all Gravix retaining walls that do not have a traffic barrier or other means to control surface runoff above the wall.

VIII. EQUIPMENT AND MATERIALS

The following is a suggested list of equipment and materials required to construct a typical Gravix retaining wall. It is important to review the construction drawings as well as the supplier material list to confirm all materials are scheduled for delivery and/or on site prior to the start of wall construction.

Equipment

- Excavator/crane (capable of lifting the respective Gravix unit weight to the heights anticipated during construction)
- Front end loader
- Compactor - both walk behind and ride-on
- Laser and hand levels
- Shovels
- Brooms
- Lifting device and supporting shackles/chains/straps

Materials

- Form boards (2 x 6) and support stakes for concrete leveling pad
- Concrete for leveling pad (20.7MPa)
- Free draining gravel for blanket drain behind the leveling pad
- Drain pipe for blanket drain
- Gravix precast concrete units
- Shims for Gravix unit placement alignment **
- 1.22m (4') wide drainage composite for vertical joints when using soil backfill. 200mm (12") wide filter fabric for vertical joints when using gravel backfill. **
- Filter fabric to encase the top portion of the blanket drain. **
- 100mm (4") wide 450g/m² (16oz/yd²) nonwoven filter fabric for horizontal joints **
- Structural backfill meeting the construction drawing specification requirements
- Erosion silt fence **
- 12mm wood spacer for setting the horizontal dimension of the vertical gap between adjacent horizontal units.
- Temporary safety fencing. ***

**** Note: Geotextile filter fabric, drainage composite, shims and adhesive must be stored out of sunlight and covered/protected/handled in accordance with ASTM D4873.**

IX. CONSTRUCTION PROCEDURES

Gravix is considered a gravity retaining wall system designed to create a stable mass to resist earth pressures and provide grade separation. Proper construction installation is important for good alignment and an aesthetically pleasing appearance of the completed structure. Following are suggested guidelines to help and assist with the installation of the Gravix gravity retaining wall system. (FIGURE 1)

First, the contractor should verify that the following are in place and scheduled prior to starting the actual Gravix construction:

- Personnel responsible for construction have reviewed all of the plans, specifications, contract documents and this installation procedure manual.
- Preconstruction meeting is scheduled and everyone involved with the construction process attends.
- All local utilities in and around the retaining wall area have been located and there are no conflicts with the proposed retaining wall geometry.
- The necessary retaining wall and land disturbance permits have been obtained.
- Drainage and site runoff prior, during and following the wall construction are observed and any potential erosion concerns addressed.

Crew Size

- A typical Gravix retaining wall installation crew will include the following personnel:
- One working foreman to oversee construction, verify alignment, quality control, etc.
- One operator for excavator/crane for setting units and backfill placement
- Three men for setting units, installation of joint materials and operating compaction equipment
- One front end loader operator for delivery of structural backfill and transporting units.

Note: Production rates are typically controlled by the speed of placing and compaction of the structural fill within and around the Gravix units.

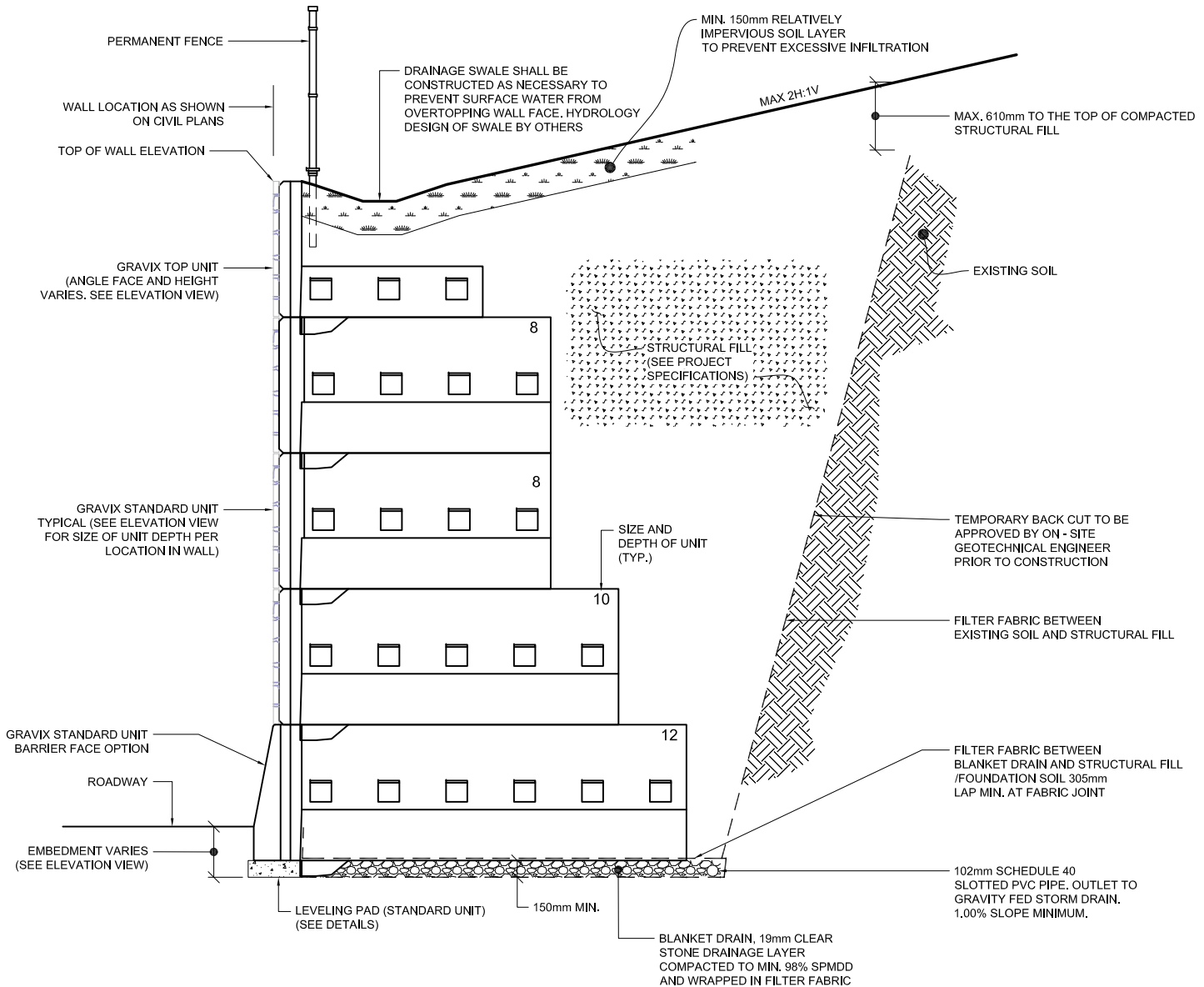

FOUNDATION REMEDIATION AS REQUIRED BY ON-SITE GEOTECHNICAL ENGINEER TO OBTAIN STABLE WORKING PLATFORM MEETING REQUIRED BEARING CAPACITY AS FOUND ON RESPECTIVE WALL ELEVATION VIEW.

TYPICAL CUT CROSS SECTION

FIGURE 1a

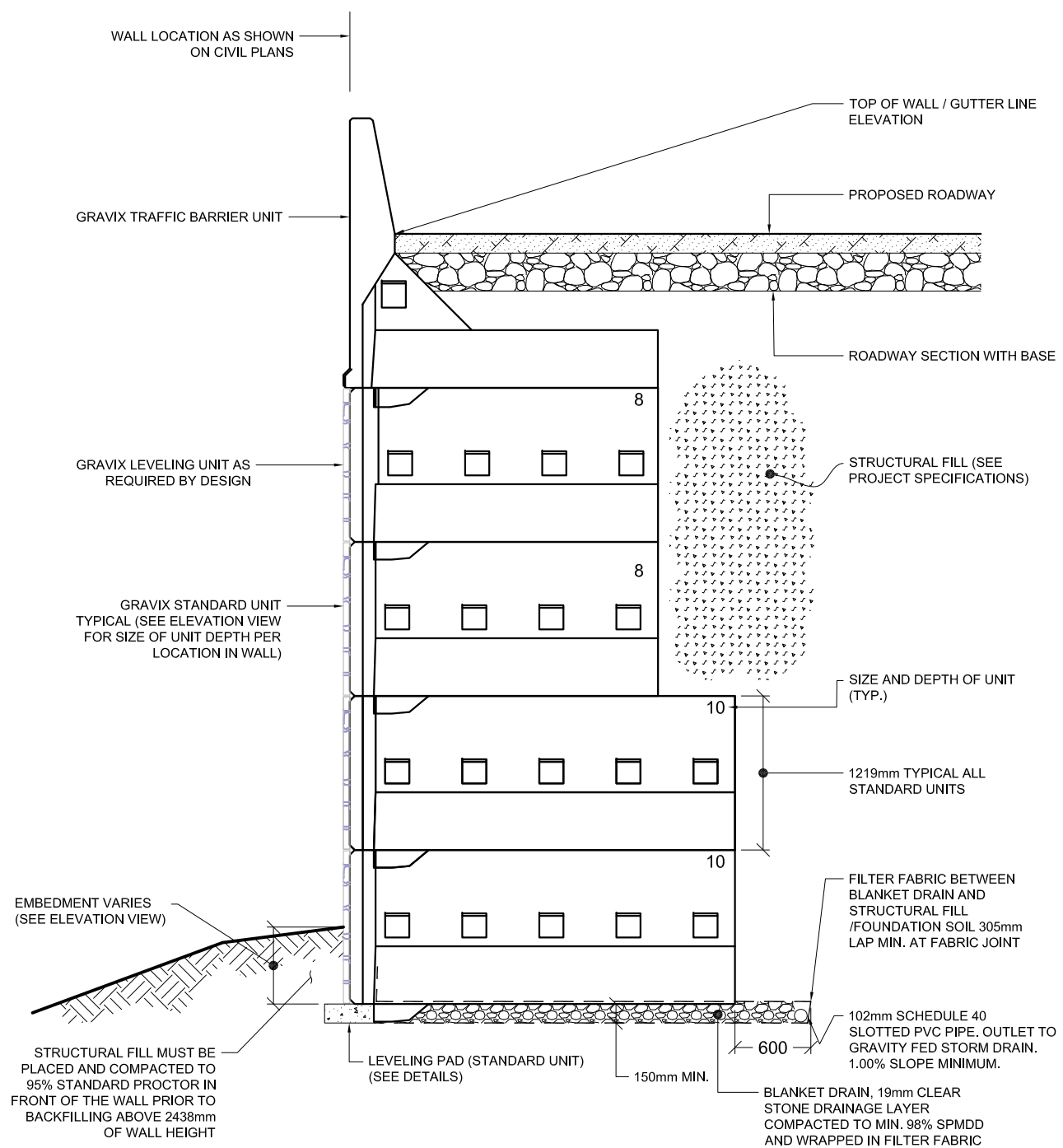

FOUNDATION REMEDIATION AS REQUIRED BY ON-SITE GEOTECHNICAL ENGINEER TO OBTAIN STABLE WORKING PLATFORM MEETING REQUIRED BEARING CAPACITY AS FOUND ON RESPECTIVE WALL ELEVATION VIEW.

TYPICAL FILL CROSS SECTION

FIGURE 1b

Step I

Survey

A field survey for the wall location and elevation must be performed and in place prior to the start of wall construction. Once the survey stakes are in place showing both proposed wall location and elevation, the concrete leveling pad may be laid out and installed.

Typically it is best to begin the proposed retaining wall construction location in the lowest point in elevation of the entire wall. The construction should then progress up in elevation building from the low point. Also, working from a corner or turn in the wall is easier to control the turn or corner point location.

Step II

Concrete Leveling Pad Installation

Working from the survey stakes in place, excavate for the 300mm (12") wide leveling pad. (FIGURES 2 & 3) Use caution not to over-excavate beyond the depth needed for the leveling pad to avoid having to reinstall and compact soil beneath the bearing surface of the concrete leveling pad or blanket drain. When excavating for the proposed retaining wall and leveling pad, be sure to slope or shore the excavation as necessary for safety and conformance with applicable MOL requirements. The excavation should be made to accept the longest stem depth at each respective wall section and location as called for on the design drawings. Under special conditions, the excavation for the wall may be done in increments or stages to minimize the amount of open cut.

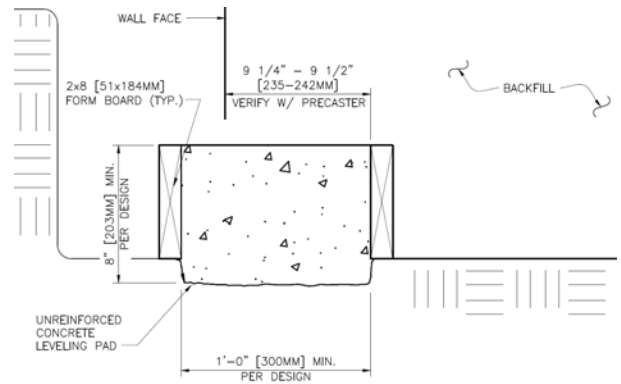

LEVELING PAD CROSS SECTION (STANDARD UNIT)

FIGURE 2

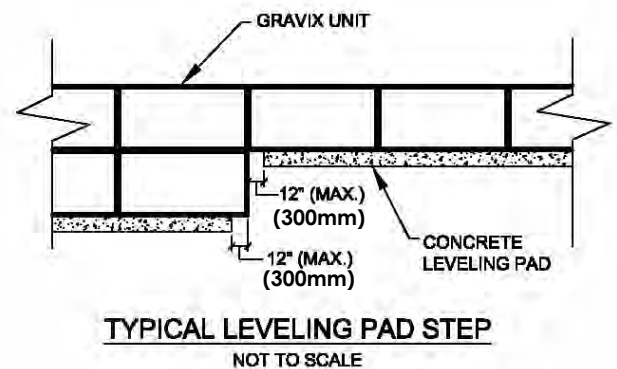

TYPICAL LEVELING PAD STEP

NOT TO SCALE

FIGURE 3

Note: The foundation soils shall be observed by the project geotechnical engineer to confirm that the bearing soils meet the design criteria. The bearing capacity required of the soils to meet the design intent must be verified prior to the pour of the leveling pad by the geotechnical engineer. Any unsuitable soils shall be replaced at the direction of the geotechnical engineer.

The actual front face of the retaining wall will be determined by the Gravix unit node resting directly behind the back of the concrete leveling pad. Therefore, the rear form board location of the concrete

leveling pad will need to be set first from the survey stakes. The Gravix unit's nodes are 200mm (8") behind the front face. Therefore, the rear form board of the concrete leveling pad must be 200mm (8") behind the proposed wall location. (FIGURE 4)



FIGURE 4

The completed concrete leveling pad is 300mm (12"). Once the rear form board is located to the correct wall face placement, the front form board can be located to provide a total 300mm (12") wide concrete leveling pad. Both horizontal and vertical placement of the form boards must be confirmed to meet the wall site layout. Support stakes should be installed to provide adequate side support and confinement for the concrete pour. Once the concrete leveling pad forms are in place and supported for concrete placement, the concrete pour can begin. (FIGURE 5) The finish concrete surface of the leveling pad should be wood float and have a tolerance of within 6mm (1/4") over 3m (10').



FIGURE 5

Remove the form boards once curing has completed and prior to blanket drain/leveling stone placement. (FIGURE 6)



FIGURE 6

Step III

Install Blanket Drain

The blanket drain's free draining stone should be kept clean of foreign materials. The blanket drain should be raked smooth to provide a level surface for complete contact with the first course Gravix unit stem. (FIGURE 7, 8 & 9) The outlet pipe at the rear of the blanket drain should be piped to gravity feed to a field located outlet or as prescribed by the construction drawings, prior to placement of the free draining stone first row of Gravix units.



FIGURE 9

Clean the leveling pad prior to placement of the first Gravix unit row and confirm the top of the blanket drain stone is level. (FIGURE 10 & 11)



FIGURE 7

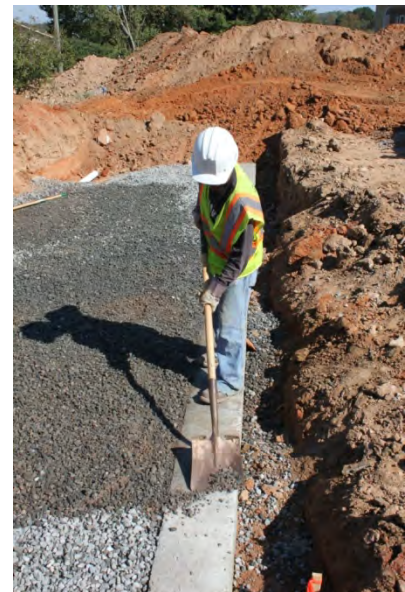
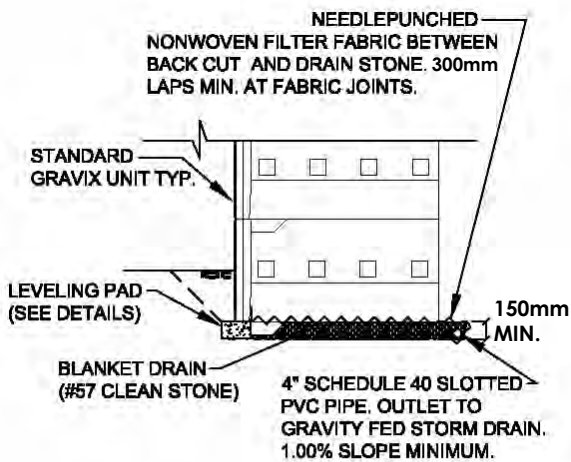

FIGURE 10



DRAINAGE BLANKET DETAIL
NOT TO SCALE

FIGURE 8

Step IV

Set First Row of Gravix

Adequate construction site turn area must be confirmed prior to arrival of delivery trucks with Gravix units. Planning for a large truck to access the construction site for unloading the Gravix units is important. (FIGURE 13)



FIGURE 13

Units are typically shipped on a flatbed tractor trailer. Coordination of Gravix unit delivery for placement directly into the retaining wall will speed up construction and limit storage area of Gravix units at the construction site. Loading and unloading of units at DECAST or in the field can be performed with conventional construction equipment. (FIGURE 14, 15 & 16) Placement in the retaining wall must be by lifting the unit from above to allow proper node installation. Movement of units when not being placed onto the wall however, can be performed using a conventional forklift. Conventional construction equipment may be used to unload the Gravix units upon arrival at the jobsite.



FIGURE 11

Prior to placement of the first course Gravix units, locate the area where nodes will rest behind the concrete leveling pad and excavate a portion of the blanket drain/leveling stone to prevent obstruction of the node. The nodes are 125mm (5") deep and approximately 150mm (6") wide, 450mm (18") long each separated by a 125mm (5") gaps. (FIGURE 12)



FIGURE 12



FIGURE 14



FIGURE 15



FIGURE 16

A Gravix lifting device is available designed to lift the different respective stem sizes to keep the unit level during placement. The lifting device will speed unloading and placement of the Gravix unit but is not required. (FIGURE 17 & 18)



FIGURE 17



FIGURE 18

Inspect the Gravix units for any signs of imperfections and damage prior to unloading the units. Refer to the construction drawings under "Manufacturing Specifications" for guidelines on conformance versus nonconformance imperfections. The materials should be protected from excessive mud, concrete, adhesives and other substances that may alter the aesthetic or functionality of the Gravix units.

Note: Upon placement of the blanket drain/leveling stone; a check should be made to get the stone as level as possible to minimize adjustments once the unit is being hoisted into place.

Place the first Gravix unit with the nodes being placed directly on the rear side of the concrete leveling pad. (FIGURE 19) Notice the areas excavated to receive the nodes to expedite placement installation.



FIGURE 19

Minor adjustment of the leveling pad stone may be required to level the first row of units. (FIGURE 20 & 21) It is important to get the first course level to minimize adjustments to level subsequent rows of Gravix units. No horizontal joint material is

required between the leveling pad and the first course unit.



FIGURE 20



FIGURE 21

The second Gravix unit placement should be installed in alignment with the first unit. (FIGURE 22) The first course level and alignment is the most important to ensure accurate and acceptable finished wall alignment results. Leveling should be done by means of a level across the top of the unit, both directions. It is best to construct the wall in level courses for the entire wall length, if possible.



FIGURE 22



FIGURE 24

The vertical joint between adjacent units must be 12mm wide. A piece of 1x4 wood spacer is typically used to set the gap of the horizontal joint to 12mm. (FIGURE 23)



FIGURE 23



FIGURE 25

Confirmation of the wall face location must be made after the first few units are installed. (FIGURE 24, 25, 26 & 27) We recommend, the original survey stakes be left in place.

Step V

Backfill Placement



FIGURE 26

A 203g/m² (6oz/yd²) nonwoven filter fabric is required between the blanket drain/leveling stone and the soil structural backfill. (FIGURE 28) Overlap all fabric edges a minimum of 150mm (6").

Note: MTO requires Granular A or B backfill within reinforced soil zones, unless contract states otherwise



FIGURE 28

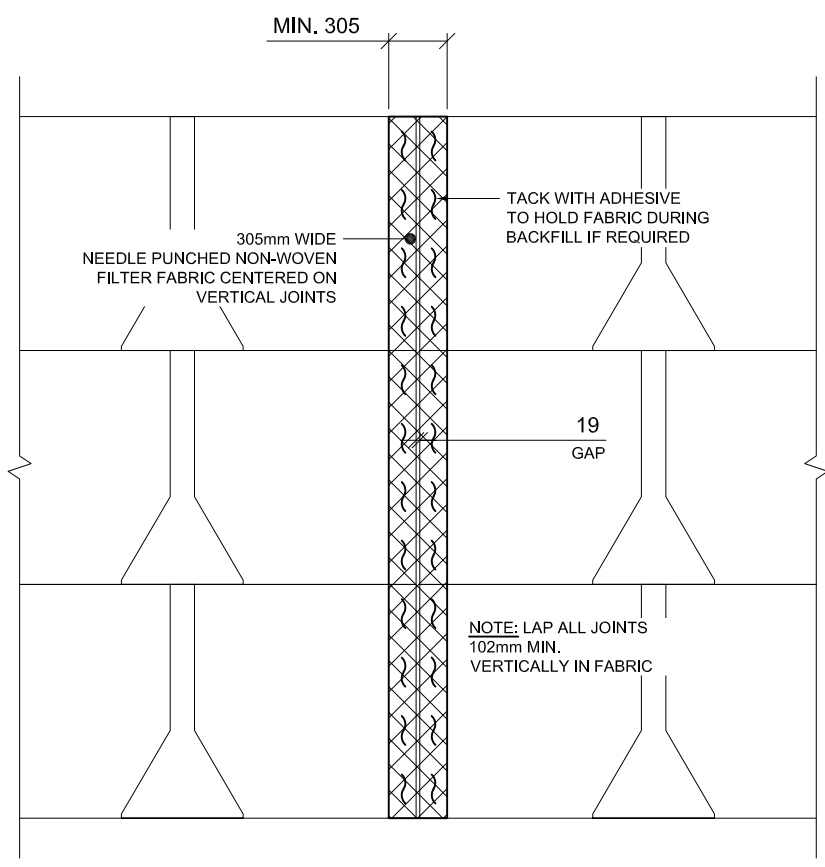

FIGURE 27

The placement of the 1.22m (4') wide drainage composite covering the vertical unit joint is tucked under the 203g/m² (6oz/yd²) nonwoven filter fabric that is placed above the blanket drain and leveling stone. (FIGURE 29, 30 & 31)



FIGURE 29



FILTER FABRIC SPECIFICATION:

FILTER FABRIC SHALL BE CLASS 1 NON-WOVEN GEOTEXTILES AS SPECIFIED IN OPSS. PROV 1860.

FIGURE 30

Compaction requirements within restricted zones behind retaining walls must conform to OPSS.PROV 501. Due to the proximity of the stems and back face of the retaining wall, only hand operated vibratory type compaction equipment shall be used to compact fill material within/between the Gravix® unit structure.



FIGURE 31

Note: Care must be taken to confirm displacement during structural backfill placement does not occur of the nonwoven filter fabric separating the blanket drain from the structural fill and the drainage composite behind the vertical Gravix unit joint.

Placement of structural backfill must be installed along the entire row of units at uniform lifts to prevent shifting of the Gravix unit stems.



FIGURE 32

Soil backfill should be dumped behind and within the Gravix units. (FIGURE 32) Dump the structural backfill material directly on the stems to fill both sides equally and

prevent lateral movement of the unit. (FIGURE 33) Gravix units should be constructed horizontally one course at a time. However, if sections of the retaining wall are constructed in staged sections, caution should be taken since the vertical height distance of structural backfill between adjacent stems is more than one unit, the unit may shift due to the unbalanced earth pressure.



FIGURE 33

The soil is typically placed in uniform 200mm (8") lifts and compacted using conventional compaction equipment. Conventional compaction rollers and hand operated compactors are typically required within or between the Gravix units. (FIGURE 34) Compaction testing is required to confirm compaction is sufficient to meet the construction drawing and project specification requirements. Do not stack the units more than one unit high without backfilling. Subsequent lifts of structural fill must not exceed the typical allowable 250mm (10") loose/200mm (8") compacted lift thickness. The lift thickness must be uniform and at the same elevation as the adjacent units to prevent shifting of units with respect to one another.



FIGURE 34

Excessively wet/dry and or non-uniform soils not meeting the project specifications shall not be used as backfill. However, below are some suggestions that can be used by the project Geotechnical engineer upon his/her approval:

- For excessively dry soils, water shall be added to the soil and mixed to within 2% of its optimum moisture content and confirmed by the Geotechnical engineer.
- For excessively wet soils, these soils may require aeration, diking and drying until they are within 2% of its optimal moisture content and confirmed by the Geotechnical engineer.
- For non-uniform soils, as directed by the Geotechnical engineer, these soils may be mixed by diking with other excavated soils or borrow soils to achieve properties consistent with the design specifications. Testing of these soils shall be performed by the Geotechnical engineer in accordance with the design specifications.

Backfill and compact the backfill in front of the retaining wall before the wall is constructed higher than two courses or 2.44m (8') in height.

The area to receive horizontal joint 100mm (4") wide, 450g/m² (16oz/yd²) nonwoven filter fabric must be swept clean prior to placement. (FIGURE 35) Also, the top of the stem must be free of materials which could prevent intimate contact of the stem surfaces.



FIGURE 35

Horizontal joints have a 100mm (4") wide layer of 450g/m² (16oz/yd²) nonwoven filter fabric to provide a filter or gasket between units to prevent loss of backfill soil but to allow water to drain out between units. (FIGURE 36, 37 & 38) The horizontal joint material should be placed 12mm (1/2") inch from the exposed front face edge.

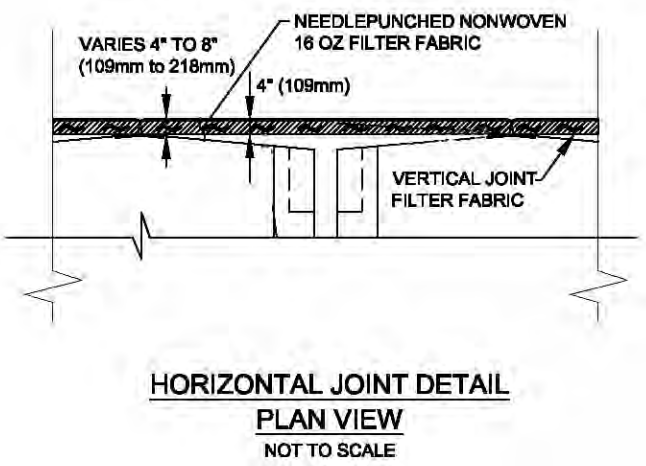

FIGURE 36

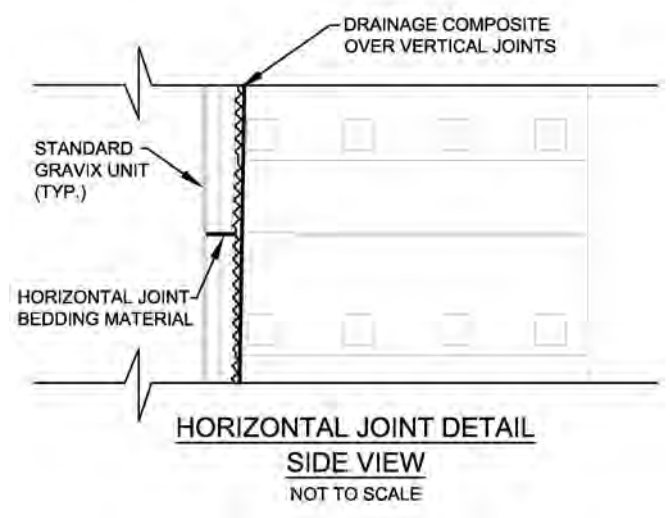

FIGURE 37

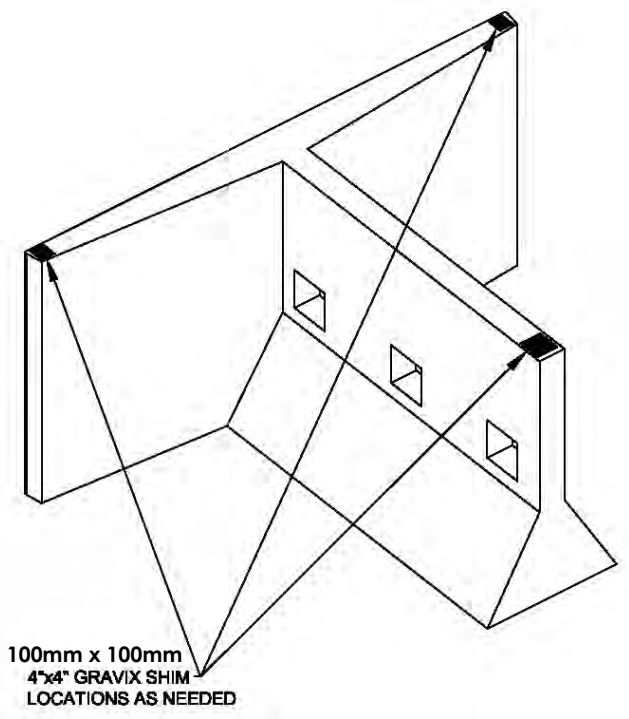

FIGURE 38



FIGURE 39

Shims may be required to provide a level platform on which additional Gravix units are to be placed. Verify a level surface prior to the next row of unit's placement. (FIGURE 39) To plumb the front face of a unit, shim the rear of the stem.(FIGURE 40) After aligning the front face, check the top of the front face for level and height with relation to the other units in the respective course. Shim as necessary and as adjustments are made, recheck alignment. (FIGURE 41) Level and plumb to make sure you have not disturbed adjacent units while adjusting others. The contractor should sight down the tops of the units to give a visual check and fine tune overall alignment of the wall units. Every effort should be made to ensure the first course of units are properly leveled and aligned. Typically, when the first course is properly installed, no adjustment or shimming is required.



VERTICAL SHIMMING
NOT TO SCALE

FIGURE 40

Gravix shims, 100mm x 100mm x 3mm (4" x 4" x 1/8") thick, may be used at the front of nodes should adjustment in the alignment be required. (FIGURE 41 & 42) Care should be taken during placement to prevent the movement of shims. (FIGURE 43)

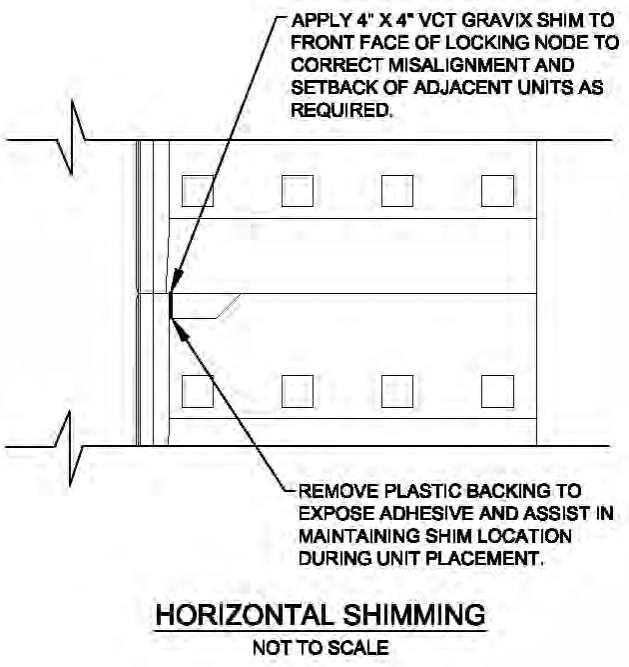

FIGURE 41



FIGURE 42



FIGURE 43

For placement of the second row of Gravix units, the nodes are angled to guide and assist in the proper placement location. (FIGURE 44)



FIGURE 44

Note: Provide temporary swales to divert runoff away from wall excavation and away from the wall surface during the construction phase.

Top Unit Placement

Careful lifting of unlevel and non-symmetric Top units will require additional lifting inserts for handling in a horizontal position for placement.



FIGURE 45

Option

Stone Backfill

Stone backfill may be used where compaction of structural backfill is difficult or placement of self-compacting stone is preferred. The stone should be placed up to and even with the top of the Gravix units. Do not overfill the unit height until a second row is installed. (FIGURE 45 & 46)



FIGURE 46

FILTER FABRIC SPECIFICATION:

Weight (oz/ty) (g/sm)	ASTM D5261	6.0 (203)
Permeability sec -1	ASTM D4491	1.5
AOS US Sieve (mm)	ASTM D4751	70 (0.212)
Grb Elongation (%)	ASTM D4632	50
Trapezoid Tear Strength lbs (kN)	ASTM D4533	60 (0.267)
Grb Tensile lbs (kN) (0.711)	ASTM D4632	160
Puncture Resistance lbs (kN)	ASTM D4833	90 (0.400)
UV Resistance %/hrs	ASTM D4355	70/500
Water Flow gpm/sf (l/min/sm)	ASTM D4491	110 (4480)
Mullen Burst psi (kPa)	ASTM D3786	305 (2103)
CBR Puncture Resistance lbs (kN)	ASTM D6241	410 (1.82)

300mm (12") WIDE
NEEDLEPUNCHED NONWOVEN
FILTER FABRIC CENTERED ON
VERTICAL JOINTS

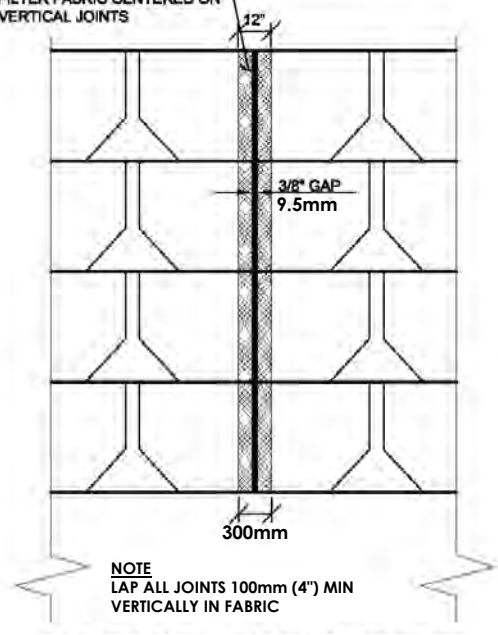

FIGURE 47

Overlap of 150mm (6") minimum is required of the 600mm (12") wide vertical joint nonwoven filter fabric. (FIGURE 47) Throw the excess filter fabric over the top of the units during backfilling and pull it back on the backfill during unit setting operations.



FIGURE 48

Excavation of a small area is required for unobstructed node placement when placing Gravix units. (FIGURE 48 & 49)



FIGURE 49



FIGURE 50

Note: A review of the final grading should be made to confirm no ponding on top of the completed structure and adequate drainage is in place to route temporary and permanent runoff around the completed structure.

REPAIR DETAIL

For areas less than 300mm x 300mm

- 1, Saw cut edges around the damaged areas. Edges will have a 10mm straight cut so as to create a 'seat' for new material.
- 2, Remove all loose concrete using a chipping hammer or hand tools as per OPSS 928 and abrasive blast clean all concrete surfaces to be patched according to OPSS 929 and 930
- 3, Any spalls have more than 30mm in depth, insert stainless steel wire mesh and stainless steel anchors as allowed creating a mechanical fastening for additional bonding to the repair material (5mm x58mm Hilti Kwik-Cons or Tapcons).
- 4, Remove all dust and loose material from the prepared surface by using compressed air.
- 5, Dampen surface with clean water as directed by SikaTop123 Plus manufacturer's instructions attached.
- 6, Trowel Sika Top 123 Plus against repair area at 38mm maximum lifts at any one time as directed by manufacturer's instructions.
- 7, Cure as appropriate for current weather conditions as directed by manufacturer's instruction.

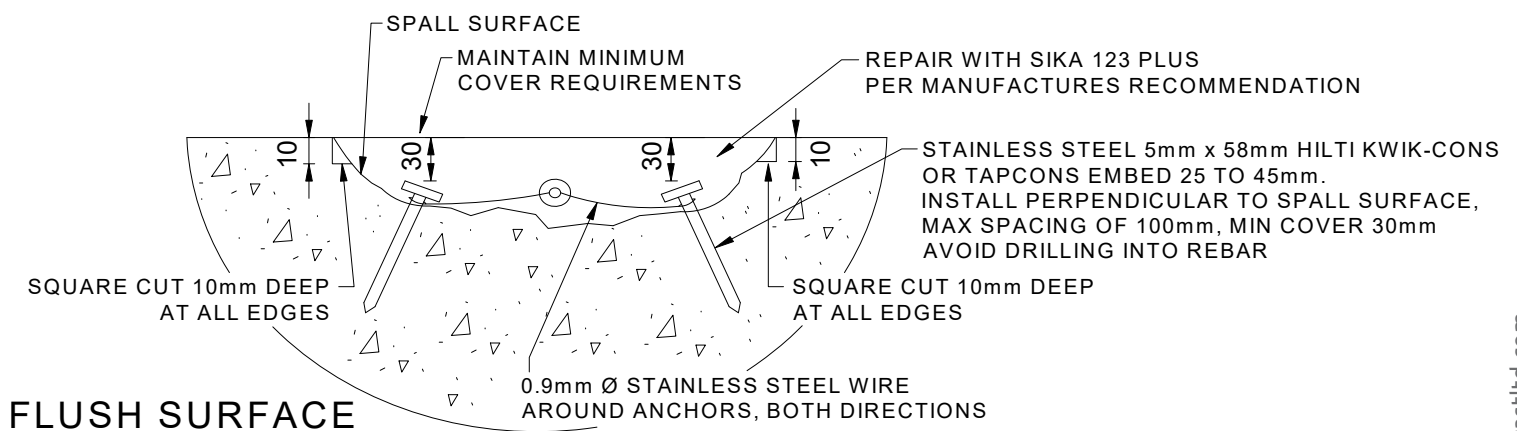
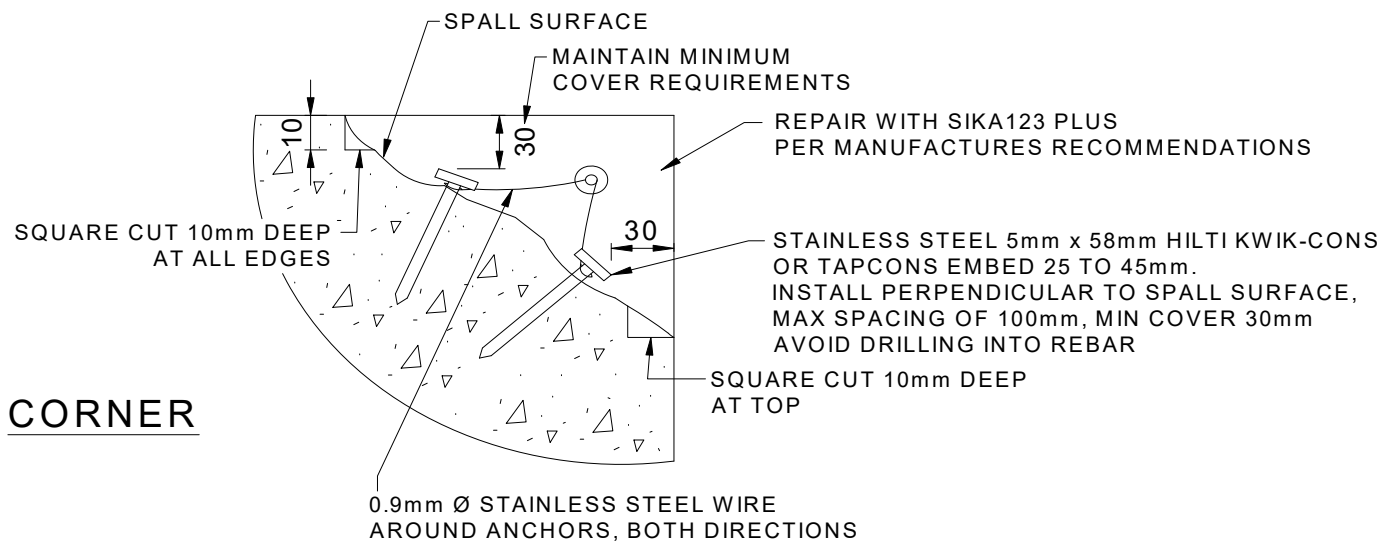

BATTERED STRUCTURES

Gravix units may be used to construct battered retaining walls following the procedures and suggested guidelines as outlined in this manual. The inclination of the leveling pad and initial course of units is critical.

The top of the leveling pad is not level across front to rear when using a battered geometry. The leveling pad will need to be poured to the same geometry equal to the batter as detailed in the design drawings and specifications. (FIGURE 51) The bottom of wall elevation and location must be verified to meet the design intent. A template wedge is typically constructed to attach a level for ease of alignment check and plumb. (FIGURE 52)

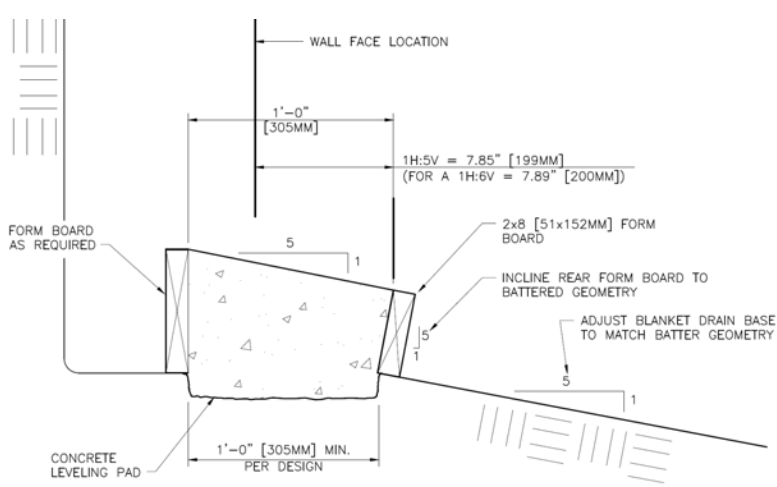

NOTE: THE ABOVE DETAIL IS DRAWN USING A 1H:5V BATTER. ADJUST THE BATTER THROUGHOUT FOR OTHER DESIGN BATTERS.

BATTERED WALL LEVELING PAD DETAIL

FIGURE 51

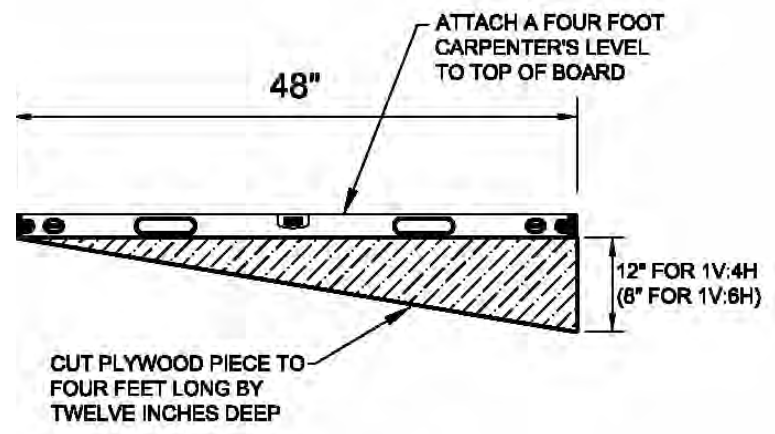

BATTERED WALL TEMPLATE
NOT TO SCALE

FIGURE 52

CONSTRUCTION TOLERANCE

Construction tolerance must be understood and accepted by the engineer, contractor and owner prior to wall construction. Agreement of acceptable tolerances prior to construction enables both the owner and contractor to have an understanding of acceptable limits. Below is an outline of typical acceptable limits of completed wall tolerances:

- Overall batter: 2.0 degrees +/-
- Horizontal alignment 38mm (1.5") as measured over 3m (10') span
- Vertical alignment 38mm (1.5") as measured over 3m (10') span

TROUBLESHOOTING

Proper construction installation is imperative to a successful Gravix retaining wall. When problems or misalignment arises, it is important to immediately correct the misalignment prior to continuing construction. Continuing construction can exasperate the situation and make the correction later much more difficult. Therefore, constant inspection and checks for plumb and levelness of the units will catch and allow the installation contractor to make minor adjustments so the finish retaining wall is within acceptable tolerances. Below is a guide for correcting issues that may arise during the Gravix retaining wall construction.

<u>Issue/Condition</u>	<u>Remedy/Cause</u>
First course not level	<ul style="list-style-type: none"> -Leveling pad not level or in proper alignment. Have survey check and correct as necessary. - Unit not within manufacturer's acceptable tolerance. Check unit tolerances with engineer of records specification requirements. - Sub-base foundation not properly prepared or compacted. Have the geotechnical engineer verify bearing and support of underlying subgrade. - Shims may be used to correct minor misalignment. - Verify no stone or foreign object is under or between adjacent units. Sweep unit surfaces prior to placement of adjacent unit.
<u>Issue/Condition</u>	<u>Remedy/Cause</u>
Horizontal out of alignment	<ul style="list-style-type: none"> -Leveling pad not level or in proper alignment. Have survey check and correct as necessary. - Foundation not properly prepared or compacted. Have geotechnical engineer verify bearing and support of underlying soils. - Shims may be used to correct minor misalignment.
<u>Issue/Condition</u>	<u>Remedy/Cause</u>
Vertical out of alignment	<ul style="list-style-type: none"> -Unit stem not properly supported by sub-base. Have geotechnical engineer verify bearing and support of underlying soils. - Unit manufacture out of tolerance. Check unit for being within acceptable manufacturing tolerance. Replace unit if out of tolerance. - Stems may be adjusted higher in the rear if the wall tends to lean into the backfill. Install shims as directed and allowed in the design to adjust stem up. - Shims may be used to correct minor misalignment.
<u>Issue/Condition</u>	<u>Remedy/Cause</u>
Unit moves upon backfilling	<ul style="list-style-type: none"> -Place backfill evenly along wall length using one lift at a time distributed evening between adjacent stems. Do not backfill between stems more than one lift higher than the adjacent void so to place lateral pressure on stem evenly.

GRAVIX RETAINING SYSTEM – FIELD INSTALLATION CHECKLIST

STEPS	INSPECTION ITEMS	YES	NO	N/A	COMMENTS
Survey	All staked locations and elevations in agreement with design				
Excavation	All utilities, structures, etc. are located prior to excavation and approval granted from governing bodies				
	Excavation requirements are met to allow for construction of wall, including required wall embedment and base depth				
	The exposed retained and foundation soil conditions meet or exceed design requirements (internal friction angle, soil type and unit weight)				
	All excavations conducted in accordance with regulatory requirements (in areas where safe excavations are not possible due to property line constraints / other structures, etc., temporary shoring may be required)				
	Presence of existing or proposed structures relative to the wall noted and designer is notified if these lie within impact zone of wall				
	If water encountered, proper dewatering techniques used to ensure dry base construction				
Foundation Preparation	The foundation soil (subgrade) meets minimum ULS and SLS bearing capacities stated in the design				
	Unsuitable soil removed and replaced under direction of site geotechnical engineer. Must include footprint of wall (including stem length). Replacement material must extend at a 1H:1V from front and back of footprint to suitable founding depth				

**MTO DSM Submission Report
Field Installation Checklist**

STEPS	INSPECTION ITEMS	YES	NO	N/A	COMMENTS
	Engineered fill material compacted to design specifications.				
Concrete Leveling Pad Installation	Leveling pad concrete is as specified in the design				
	Leveling pad dimensions are as specified in the design				
	Back face of the levelling pad is survey controlled as it impacts the alignment of the retaining wall				
	The surface is level front to back and side to side (except for battered walls, then slope should be verified)				
	Leveling pad stepping as per design to ensure minimum required embedment is maintained at all times				
Blanket Drain Installation	Blanket drain material is as specified in the design				
	Blanket drain material raked smooth to ensure complete contact with the first course Gravix unit stem				
	Blanket drain compacted to a dense state				
	Locate node placement areas to excavate portion of blanket drain to prevent obstruction during first coarse placement				
Drainage Conduits	The size and type of drainage pipes as per design				
	The width of drainage fill at the wall back not less than specified				
	The drainage pipe elevation meets design				
	Outlet spacing and locations as per design				

**MTO DSM Submission Report
Field Installation Checklist**

STEPS	INSPECTION ITEMS	YES	NO	N/A	COMMENTS
Drainage Fabrics/Composites	Filter fabric placed on either side of any clear stone drainage layer				
	Drainage composite or filter fabric meeting minimum specifications and dimensions on drawings placed on back of front face of units, and tacked on with adhesive as required to prevent movement during backfill placement				
	Horizontal filter fabric layer placed between the front face of all units				
Unit Placement	The units used on site are as specified (stem length, standard vs. custom top units, no imperfections, etc.)				
	Wall construction should start from the lowest vertical location and steps up as required and/or start at an existing structure or corner				
	All units in full contact with the units below				
	Units leveled side to side and front to back				
	All debris cleaned off the top of the units before installing the subsequent course				
	Check the level and alignment of the units, especially at curves, corners, as per design				
	Vertical spacing in between units is as specified in the drawings				
	Units are stacked no more than one unit high before backfilling				
	Backfill is placed equally on both side of the stems to prevent tilting/lateral movement				
	Alignment checked periodically to ensure conformance to design				

**MTO DSM Submission Report
Field Installation Checklist**

STEPS	INSPECTION ITEMS	YES	NO	N/A	COMMENTS
Backfill Materials	The soil backfill material within and behind the units meets the design requirements (specified gradation/material properties)				
	Maximum compaction lift thickness is as per drawings				
	Soil compacted to minimum in-situ density as specified				
	No compaction equipment over 2 tons to be used between the Gravix stems				
Cap Soil	The material is as per specification				
	Final grading to prevent water from collecting behind the wall, as per design				
	Clean up site to finish the construction				
Other	All other elements to incorporated as per design				
	Contractors installing other non-wall related structures that impact the wall must be notified of potential impacts and limitations of wall prior to commencing work				



SALES

sales@decastltd.com

ENGINEERING

engineering@decastltd.com

INFO & INQUIRIES

info@decastltd.com



DECAST Ltd.

8807 County Road 56

Utopia, ON L0M 1T0

1.800.461.5632

705.734.2892



WEB

www.decastltd.com

DECAST

decastltd.com