

DECAST



OPTIMIZE
LAND USE



LARGE STORAGE
CAPABILITIES



FAST & EASY
INSTALLATION



ENGINEERED FOR
HEAVY LOADS

GROTTO STORM™

GROTTO · 

PATENT PENDING



GROTTO STORM™
BROCHURE
DOWNLOAD

INTRODUCING GROTTO STORM™

**A precast concrete solution
for shallow stormwater
management applications**

- Designed to the Canadian Highway Bridge Design Code (CHBDC), CSA S6-19
- Allows up to 2m of earth cover
- Capable of supporting parks, playgrounds, roads, parking lots and other above ground applications
- Various heights available
- Footing design prevents components from twisting and shifting
- Modular system that can fit any footprint
- Can be used for both infiltration and closed-bottom systems
- Robust underground storage alternative to plastic and other concrete systems



DIMENSIONS & VOLUMES

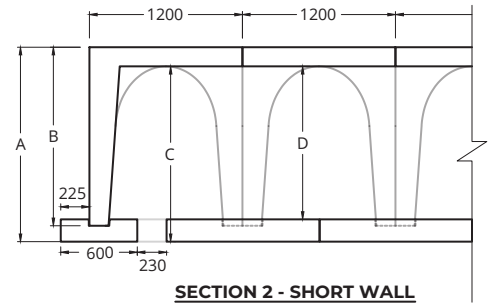
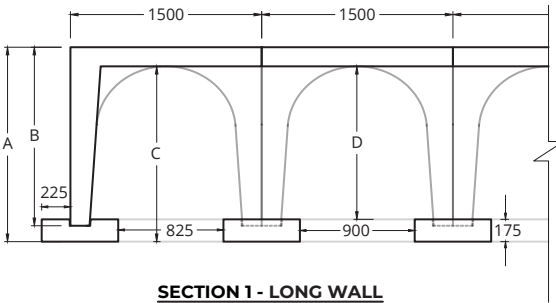
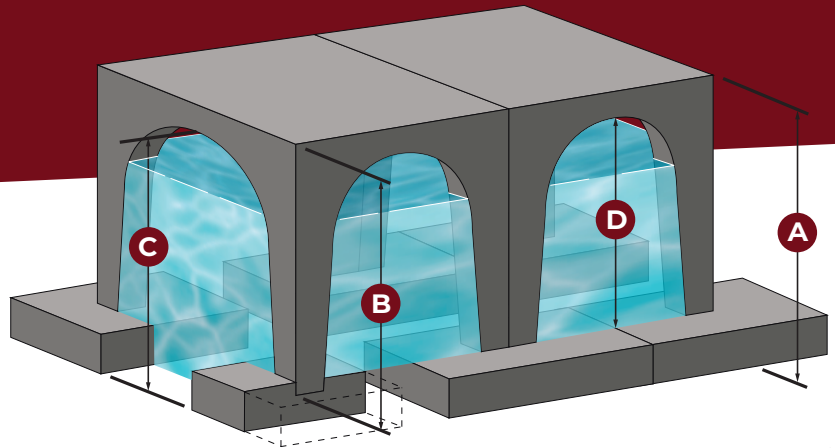

GROTTO 	HEIGHT* (mm)				CENTRE UNIT		CORNER UNIT		LONG WALL UNIT		SHORT WALL UNIT	
	A	B	C	D	VOLUME (m ³)	MASS (kg)	VOLUME (m ³)	MASS (kg)	VOLUME (m ³)	MASS (kg)	VOLUME (m ³)	MASS (kg)
GS900	1025	900	875	700	1.21	1232	0.92	1842	1.04	1585	1.11	1489
GS1100	1225	1100	1075	900	1.55	1293	1.18	2073	1.33	1744	1.42	1622
GS1400	1525	1400	1375	1200	2.05	1367	1.59	2385	1.78	1954	1.88	1798

*more height options available upon request

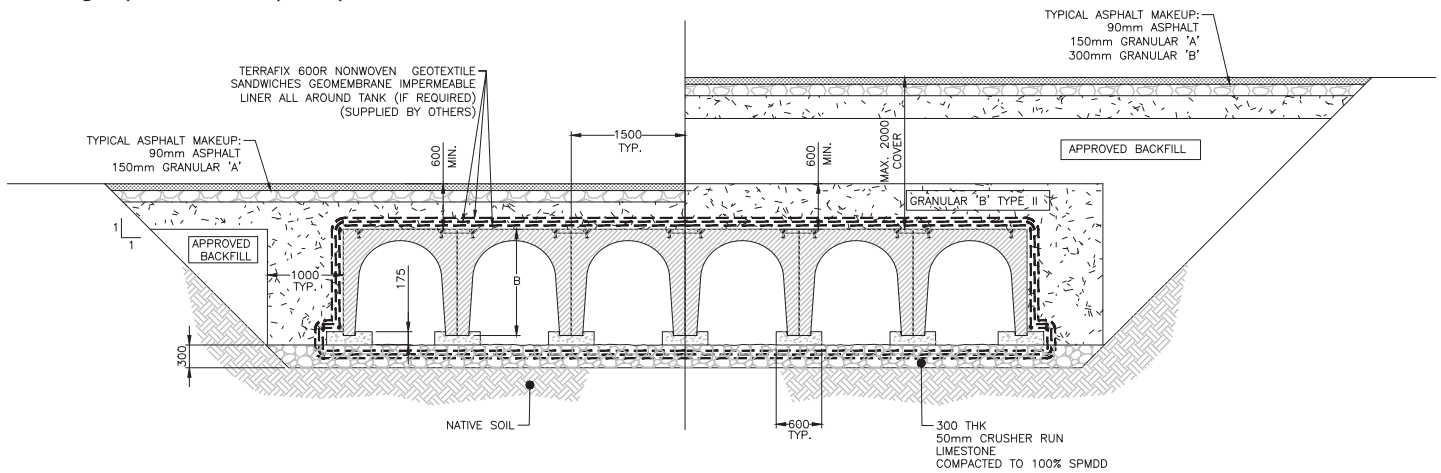

visit decastltd.com for more information

DECAST



DECASTLTD.COM